







Supercessions	Ref #	Part #	<input checked="" type="checkbox"/> Description	<input checked="" type="checkbox"/> Qty	<input checked="" type="checkbox"/> Context Note	<input checked="" type="checkbox"/> Foot Note	<input checked="" type="checkbox"/> UOM
	10	----- Add to pick list	Engine *			Note* For information on Replacement Parts for this engine contact the manufacturer.	
↷	12	0025X6MA Add to pick list	SCREW				Ea
	14	020062MA Add to pick list	WOODRUFF KEY 505				
↷	18	671959E701 Add to pick list	BRACKET, BATTERY		(Parts for electric start models.)		Ea
↷	19	26X220MA Add to pick list	SCREW *		(Included with Ref. No. 20)	Note* For electric start model	Ea
	20	776014MA Add to pick list	CASE, BATTERY		(Parts for electric start models.)		
↷	21	672182 Add to pick list	BATTERY *		(Included with Ref. No. 20)	Note* For electric start models	Ea
↷	22	671992MA Add to pick list	CHARGER, BATTERY		(Parts for electric start models.)		Ea
↷	50	672089E701A Add to pick list	BLADE, 21" REVERSIBLE				Ea
↷	51	043603MA Add to pick list	ADAPTER, BLADE 21"				Ea
↷	53	17X137MA Add to pick list	WASHER, BEVELLE				Ea
↷	54	17X124MA Add to pick list	WASHER				Ea
↷	55	01X148MA Add to pick list	SCREW, 3/8- 24 x 2.00				Ea
	60	071470MA Add to pick list	SPACER				
	80-20	627845E201 Add to pick list	BRACKET, HANDLE RH				Ea
↷	80-30	672844E201MA Add to pick list	BRACKET, HANDLE LH				Ea
↷	80-35	26X275MA Add to pick list	SCREW, 5/16- 18 x 0.63				Ea
↷	80-36	015X79MA Add to pick list	NUT, 5/16-16				Ea
↷	80-40	071569E201MA Add to pick list	INDEX, HEIGHT ADJ				Ea
↷	256	672271MA Add to pick list	BELT, V				Ea
↷	600	043640 Add to pick list	DEFLECTOR, REAR				Ea
↷	601	26X245MA Add to pick list	SCREW, 10- 16X.50				Ea
↷	610	071409 Add to pick list	DOOR, REAR 21				Ea
↷	611	071410MA Add to pick list	SPACER				Ea
↷	612	26X259MA Add to pick list	SCREW, 10- 16X.50				Ea

	613	672282 Z Add to pick list	ROD, PIVOT				Ea
	614	028X42MA Add to pick list	CAP, PUSH ON				Ea
	615	166X33MA Add to pick list	SPRING, TORSION				Ea
	--	F-040431L Add to pick list	OWNER'S MANUAL				

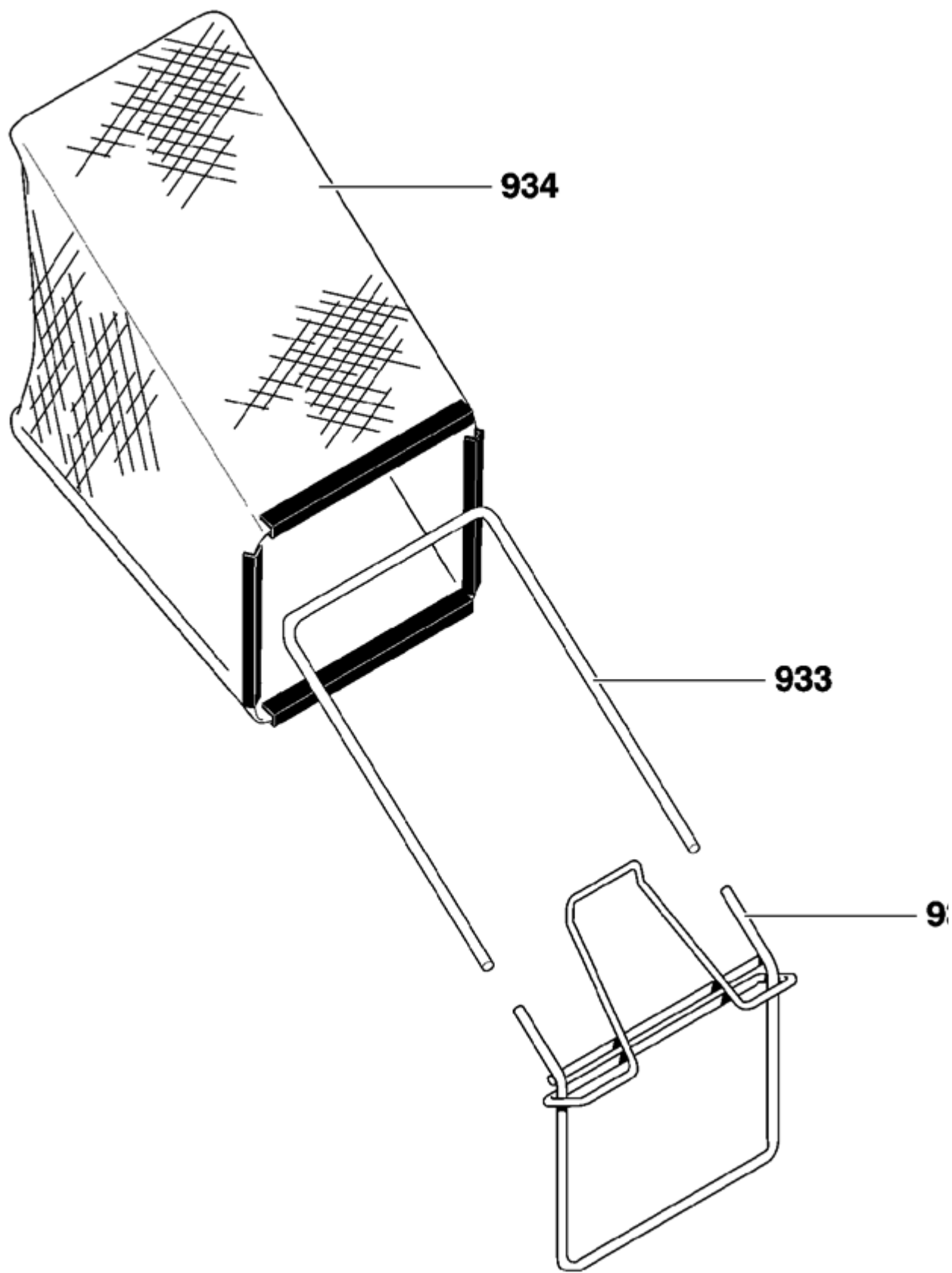



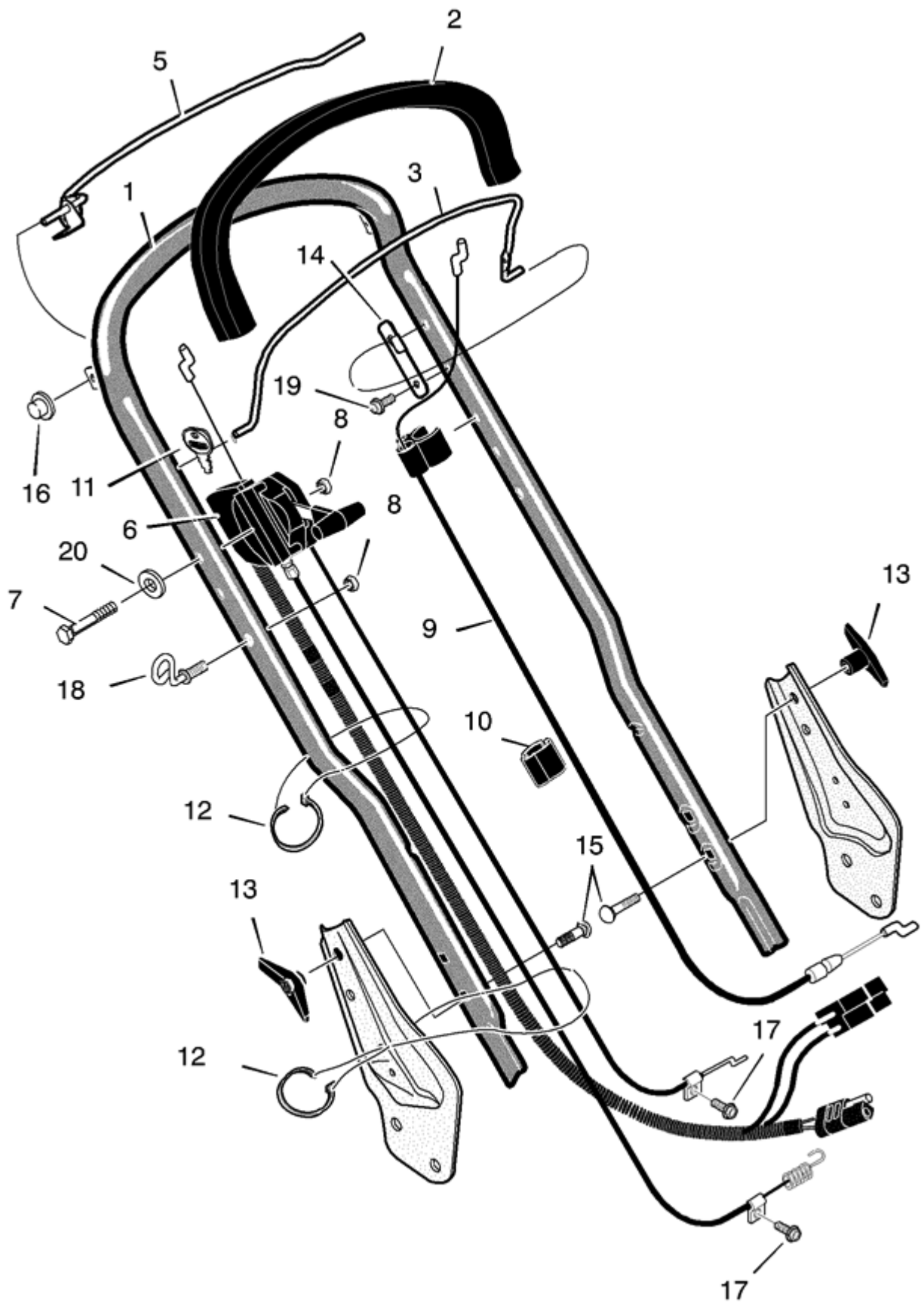



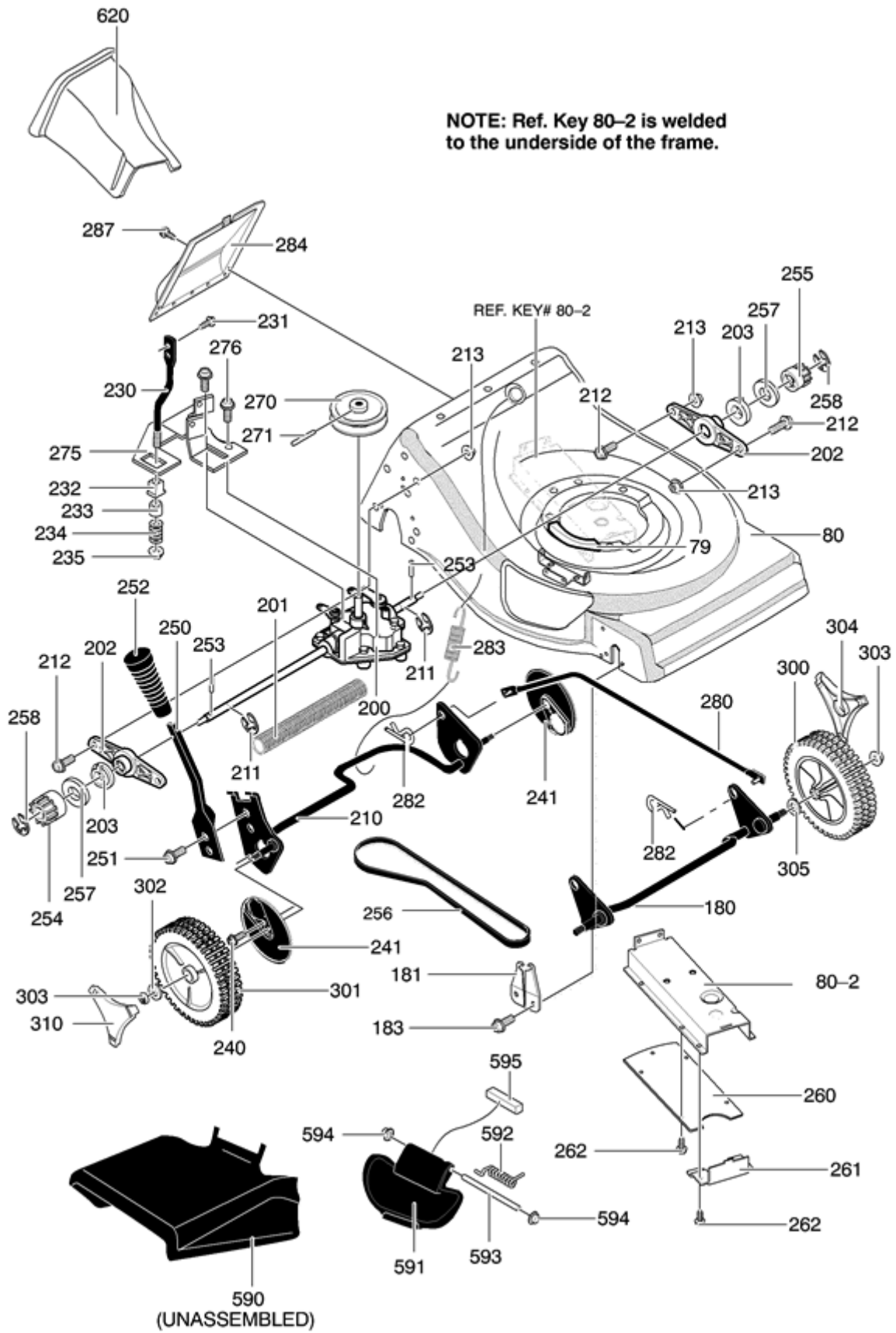









































Supercessions	Ref #	Part #	<input checked="" type="checkbox"/> Description	<input checked="" type="checkbox"/> Qty	<input checked="" type="checkbox"/> Context Note	<input checked="" type="checkbox"/> Foot Note	<input checked="" type="checkbox"/> UOM
	931	672293MA Add to pick list	ASSY, BAG FRAME				Ea
	933	071592MA Add to pick list	FRAME, BAG TOP				Ea
	934	1101950MA Add to pick list	BAG, 21"				Ea



Supercessions	Ref #	Part #	<input checked="" type="checkbox"/> Description	<input checked="" type="checkbox"/> Qty	<input checked="" type="checkbox"/> Context Note	<input checked="" type="checkbox"/> Foot Note	<input checked="" type="checkbox"/> UOM
	1	1102023E701MA Add to pick list	HANDLE, UPPER				
	2	1101765MA Add to pick list	SLEEVE, HANDLE				Ea
	3	1101766E701MA Add to pick list	LEVER, STOP				
	5	1102018E701MA Add to pick list	LEVER, DRIVE				Ea
	6	1101940MA Add to pick list	DRIVE CONTROL & CABLE				Ea
	7	001X93MA Add to pick list	BOLT				Ea
	8	15X116MA Add to pick list	NUT				Ea
	9	1101960MA Add to pick list	CABLE, STOP				Ea
	10	1101353MA Add to pick list	CLIP, CABLE				Ea
	11	672220 Add to pick list	KEYS & RING				Ea
	12	071372MA Add to pick list	STRAP, TIE				Ea
	13	071294 Add to pick list	WINGNUT				Ea
	14	1101962 Add to pick list	BRACKET, STOP				Ea
	15	002X77MA Add to pick list	BOLT, CARRIAGE				Ea
	16	028X82MA Add to pick list	CAP				Ea
	17	26X245MA Add to pick list	SCREW				Ea
	18	071530MA Add to pick list	GUIDE, ROPE				Ea
	19	26X217MA Add to pick list	SCREW				Ea
	20	017X37MA Add to pick list	WASHER				Ea



Supercessions	Ref #	Part #	<input checked="" type="checkbox"/> Description	<input checked="" type="checkbox"/> Qty	<input checked="" type="checkbox"/> Context Note	<input checked="" type="checkbox"/> Foot Note	<input checked="" type="checkbox"/> UOM
	79	712012 Add to pick list	SEAL, FOAM				
	80	071762E201MA Add to pick list	ASSY, FRAME				
	180	071152E201MA Add to pick list	CROSSBAR, FRONT				
	181	672279MA Add to pick list	BUSHING				Ea
	183	26X221MA Add to pick list	SCREW				Ea
	200	672270MA Add to pick list	TRANSMISSION				Ea
	201	043649 Add to pick list	SHIELD, AXLE				Ea
	202	071411MA Add to pick list	SUPPORT, AXLE				Ea
	203	043788MA Add to pick list	BEARING, LIFTER				Ea
	210	672277E201MA Add to pick list	ASSY, CROSSBAR				
	211	011X16MA Add to pick list	E-RING				Ea
	212	001X45MA Add to pick list	SCREW				Ea
	213	015X79MA Add to pick list	NUT				Ea
	230	071481 Z Add to pick list	SUPPORT, SPRING				Ea
	231	26X217MA Add to pick list	SCREW				Ea
	232	071480MA Add to pick list	BUSHING				Ea
	233	043844MA Add to pick list	SPACER				Ea
	234	164X27MA Add to pick list	SPRING				Ea
	235	015X88MA Add to pick list	NUT, 5/16-18				Ea
	240	26X221MA Add to pick list	SCREW				Ea
	241	643616MA Add to pick list	DUST COVER				Ea
	250	672278MA Add to pick list	LEVER, SPRING				Ea
	251	26X263MA Add to pick list	SCREW				Ea
	252	071297MA Add to pick list	GRIP, HEIGHT ADJ				Ea
	253	043629MA Add to pick list	PIN, DRIVE				Ea
	254	671904MA Add to pick list	GEAR, PINION RIGHT				Ea

	255	671903MA Add to pick list	GEAR, PINION LEFT				Ea
	256	672271MA Add to pick list	BELT, V				Ea
	257	17X186MA Add to pick list	WASHER, FLAT				Ea
	258	011X16MA Add to pick list	E-RING				Ea
	260	43770E701MA Add to pick list	COVER, BELT GUARD				Ea
	261	71239E701MA Add to pick list	COVER, FRONT BELT				Ea
	262	26X259MA Add to pick list	SCREW				Ea
	270	672269MA Add to pick list	PULLEY				Ea
	271	97129MA Add to pick list	PIN, SPRING				Ea
	275	672819 Add to pick list	BRACKET, CABLE				Ea
	276	0025X2MA Add to pick list	SCREW				Ea
	280	043721E201 Add to pick list	LINK, LIFTER ASSY				Ea
	282	0031X9MA Add to pick list	PIN, HAIR				Ea
	283	711459MA Add to pick list	SPRING, EXTENSION				Ea
	284	071246E201 Add to pick list	COVER, REAR				Ea
	287	26X263MA Add to pick list	SCREW				Ea
	300	1101114MA Add to pick list	TIRE & RIM, -FRONT				Ea
	301	672440MA Add to pick list	WHEEL, DRIVE - RR				Ea
	302	017X169 Add to pick list	WASHER, FLAT				Ea
	303	015X84MA Add to pick list	NUT				Ea
	304	672445MA Add to pick list	HUB CAP				Ea
	305	017X91MA Add to pick list	WASHER				Ea
	310	672805MA Add to pick list	HUB CAP				Ea
	590	071770MA Add to pick list	DEFLECTOR, CHUTE				Ea
	591	071769 Add to pick list	COVER, MULCH				
	592	166X38MA Add to pick list	SPRING, TORSION				Ea
	593	215X16 Z Add to pick list	ROD, PIVOT				Ea
	594	028X42MA Add to pick list	CAP, PUSH ON				Ea

595 712012 SEAL, FOAM
Add to pick list

	620 71250 Add to pick list	PLUG, MULCHER				Ea
---	-------------------------------	---------------	--	--	--	----